

BSL ZEUS

USERS GUIDE

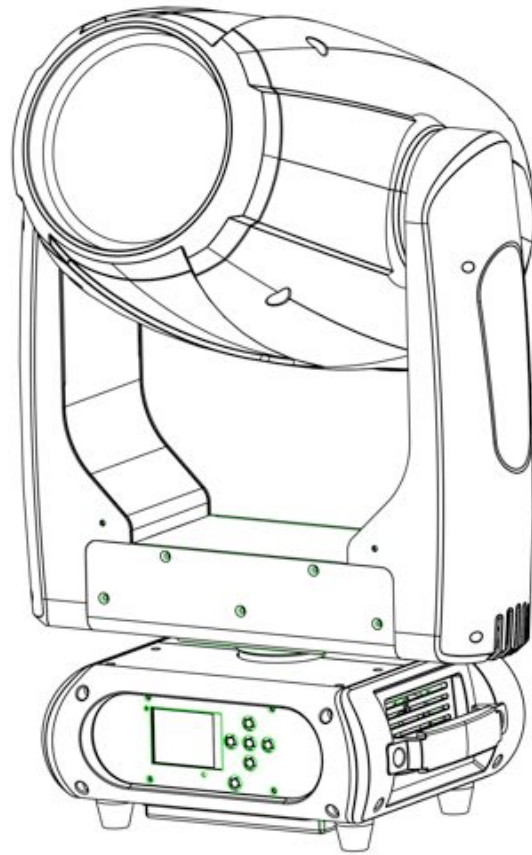

CE

1. Product Introduction:

1.1 Before unpack the fixture, pls make sure that the packing is in good condition, following items will be found in the box:

- The fixture
- This users guide
- 3m DMX cable
- 1.5m power cable with powercon
- Omega bracket for hanging installation
- Safety chain

1.2 Specification

Source

- Light source: Osram Sirius HRI 440W
- Led life: 2.000 hours
- Luminous Flux: 24000lumen, 260000lux@10m@beam, 109000lux@10m@spot
- Control: Remote on/off via DMX
- Ballast: switching mode power supply

Optical System

- Beam angle: 2°-40° beam, 3°-45°spot

X/Y

- Pan: 630° (4.0 sec) or 540°(3.58 sec), Tilt: 265° (2.8 sec)
- 3 phase motor
- 16-bit resolution
- Auto repositioning

Colors

- three color wheels with CMY fading + 15 color filters
- Bidirectional rainbow effect
- Color bounce effect for sequential colors on the wheel

Gobos

- Rotating gobo wheel: 6 dichroic, indexable and interchangeable rotating gobos
- Static gobo wheel: 18 metallic fixed Gobos (6 beam reducer)
- Animation wheel
- Real indexable and gobo shaking
- Distinctive gobo animation effect

Features

- DMX channels: 31/32/18/20
- Color wheel: CMY+15 colors
- Rotating gobo wheel: 6+1 gobos
- Static gobo wheel:18+open
- Zoom: 2°-40° beam, 3°-45°spot
- Motorized focus
- Full range 0-100% dimmer
- Various strobe
- Frost
- 6-Linear+ 3 facets prism
- RDM function to change DMX address, display flip, X/Y Reverse and so on

- RDM read voltage, current and power consumption of lamp
- Software upgrade via DMX
- Hibernation when lost DMX for preset time
- Indicate temperature info of base, arm and lamp
- Fan speed auto change according to temperature
- Artnet control

Display

- 2.4inch super nice LCD display with friendly English/ Chinese/French/Spanish menu
- Auto lock
- Flip
- Back-up communicating IC

1.3 Description of the Device

1. Project lens
2. Head
3. Arm
4. Base
5. Display
6. Foot stand
7. Operation button
8. Handle

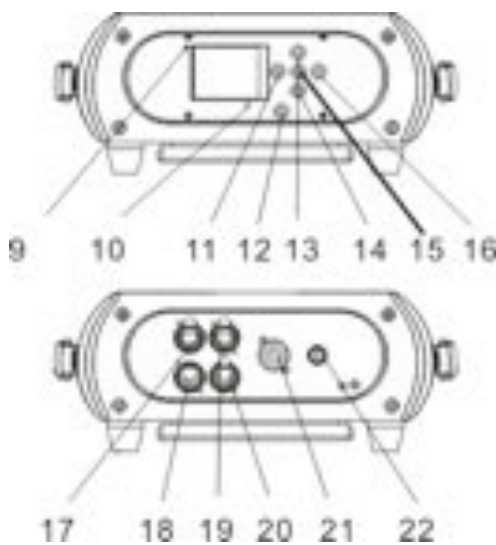
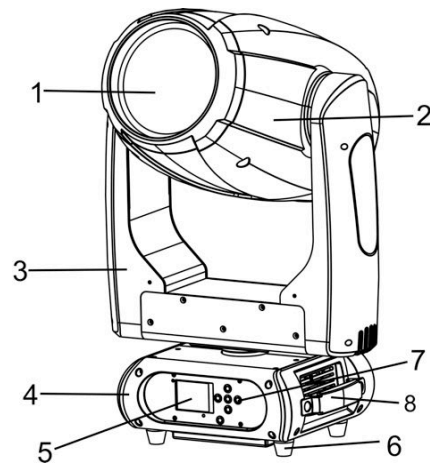

9. Wireless indicator
10. Mic
11. Left button
12. Battery indicator
13. Up button
14. Down button
15. Enter button
16. Right button
17. Ethernet out
18. 5-pin DMX in
19. Ethernet in
20. 5-pin DMX out
21. Powercon in
22. Fuse





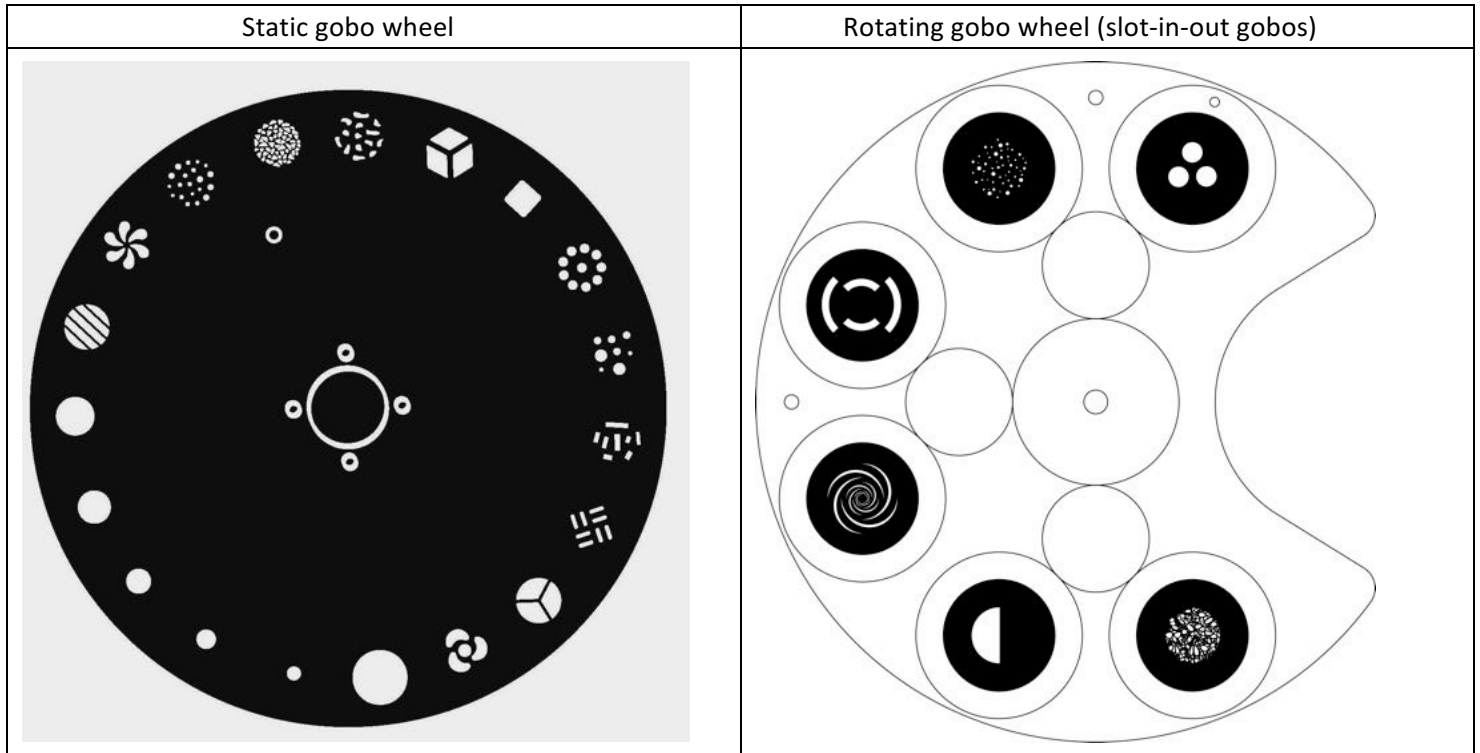



1.4 Colors and Gobos





		Open	
	1		UV
	2		Blue
	3		Dark pink
	4		Light blue
	5		Sky blue
	6		Linear Cyan
	7		Red
	8		Light orange
	9		Orange
	10		Brown
	11		Dark red
	12		Linear Magenta
	13		Green
	14		Magenta
	15		Light orange
	16		Dark Green
	17		Grass green
18		Linear Yellow	



2. Safety and maintenance Information

2.1 Safety Info

	<p>Before operate this unit, please carefully read this users guide and keep if needed in future. It's necessary to respect following rules.</p>
	<p>The disposal of the device after lifecycle could damage the environment, need to take it to special company for recycling or return to authorized dealer.</p>
	<p>The products referred to in this manual conform to the European Community Directives and are therefore marked with CE logo.</p>
	<p>Keep this device away from children and unauthorized users, the manufacturer will not take responsibility for the damage due to any disregard of the information provided in this manual and wrong operation.</p>
	<p>Before operate the device, pls make sure the fixture is in good housing, ensure pan and tilt can rotate in its complete range.</p>
	<p>Pls make sure minimal 0.5m distance need to kept between the fixture to any flammable material.</p>
	<p>The device can only run with 100-240v voltage, 50/60Hz power, don't connect to any other wrong power. Disconnect the device from main power before open the shield or maintenance.</p>
	<p>The device is designed only for indoor usage, pls keep it away from moisture. Do not expose the device under the sun or directly to any other lighting source.</p>
	<p>Never look directly into the projecting lens when the fixture is power on, the light may trigger epileptic seizures in photosensitive persons or persons with epilepsy. Especially at beam effect, extreme caution and observance of these safety instructions is mandatory.</p>

	Don't put or install the device on a surface that subject to vibration or bumps.
Ta=45°C	The device is supposed to work in the temperate range -15° C and +45° C, do not use the device when the temperate exceed this range.
	The lens, shield need to be replaced when obviously broken, never use the device when the shield is not completed closed.
	Safety I class device, need to be earth connected.
	When the fixture is hanged overhead, the safety rope must be fixed to the bottom of the device to the appropriate fixing point.
	Always carry the device by the handles, do not take the head or arm directly for transportation.

2.2 Maintenance

2.2.1 Operation only allowed to qualified person, damages due to unprofessional operation or remove of any parts inside will not be considered in warranty service. There are no serviceable parts inside the device or package, service only leaves to authorized dealers.

2.2.3 Never allow the optical components contact with oil, fat or any other liquid.

2.2.4 A regular clearance of the device is needed for long-term usage, this is very helpful to maintain the lifetime and brightness need to use a soft and lint-free cloth to clean the optical system, fan and air flowing tunnel.

2.2.5. Trouble Shooting

Problems	Possible reasons	Checking or solutions
Device not power up	Powercon or power cable damaged Faulty power supply	Change a good power cable to try Replace new power supply
Pan/Tilt error or vibrate	Faulty Pan/Tilt PCB Faulty opto sensor Cable loosen	Replace PT001 PCB Replace opto sensor OP001 Check the cable connect to OP001
Lamp off	Temperature protection Fan not working Faulty Lamp Dimmer and strobe set at 0 Faulty power supply	Check the temperature from menu Check the fan speed info from menu Replace new Lamp Set dimmer and strobe channel at 255 Replace new power supply
Device not response to DMX	Faulty communication IC Faulty display PCB Wrong DMX addressing Faulty DMX cable	Replace the IC with back-up one in the display PCB Replace new display PCB Check the address and setting Change to a good DMX cable

2.2.6 Replacement of the fuse

Need to replace with same type and rating, which originally installed in the device.

Step One: Unplug power cable from main power.

Step Two: Unscrew the fuse holder out of the housing with a screwdriver.

Step Three: Remove the broken fuse and replace with an exact same type of new fuse.

Step Four: Insert the fuse holder back to the housing and screw tight and reconnect power.

3. Installation

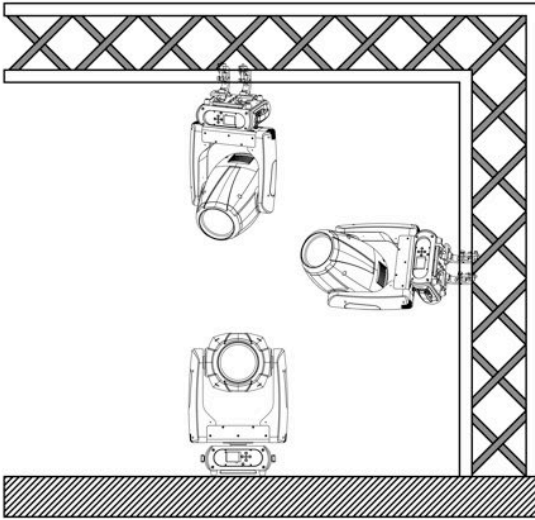

3.1 The device could be either put on a solid and even surface, or mounted upside down or sideways like left picture.

3.2 The mounting place must be sufficient stable and be able to support a weight of 10 times of the unit's weight. When the fixture is hanged, always additionally secure the device with the safety chain, fasten the safety rope at a suitable position so that the maximum fall of the projector will be 20 cm

3.3 How to do mounting installation.

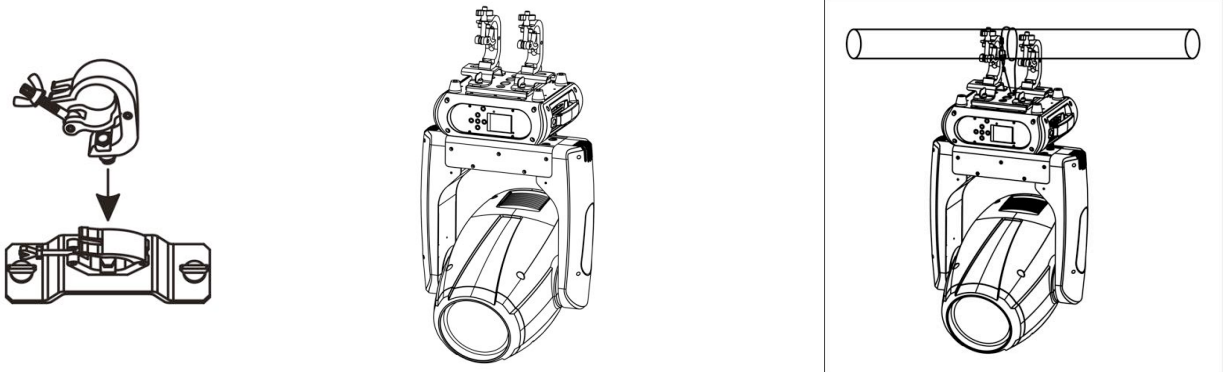

Step one: Installation the clamp onto the omega bracket;

Step two: Install the clamp and bracket on the bottom of panel, fasten the quick-locks;

Step three: Install the whole device onto appropriate truss and fasten the clamps, tight the safety rope with the truss or other fixing point at a suitable position that drop down distance not exceed 20 cm.

4. Control menu

4.1 Meaning of the icon in menu

CONNECT	LIGHT	INFOMATION	SET	PROGRAM
				

4.2 Menu tree

Default setting shadowed. Mark with ① can be basic reloaded, ② be program reloaded, ③ can be private reloaded.

Connect	DMX Address①	XXX	DMX address setting
	Wireless①	(Wireless Module)	Wireless Enabled
	Artnet①	(Only Artnet Module)	Artnet Enabled
Light	Turn On/Off Automatic DMX Control (Only HID Lamp)	ON/OFF ON/OFF ON/OFF	Turn On the lamp Lamp On/off when power on DMX control or not (HID Lamp)
	Max Temperature①	80~139°C /176~282°F	Lamp off if temperature continuously over for 2minutes
	Lamp Adjust①	PAN.....	Adjust value of channel
Information	Time Info.	Current XXXX(Hours) Fixture Life XXXX(Hours) Lamp Life XXXX(Hours) (Only HID Lamp)	Fixture boot time Fixture total run time Lamp total run time
	Lamp Info. (Only HID Lamp)	Voltage Current Power	HID Lamp Information (HID Lamp)
	Temperature	Near Lamp Temp (depends on fixture)	Temperature Sensors
	Fans Speed	Near Lamp Fan (depends on fixture)	Fan speed Sensors
	Channel Value	PAN.....	Display value of channel
	Error Message	Pan,Tilt.....	Error channels
	Fixture Model	xxxxxxxxxxxx	Display model brand and model
Software Ver	1U01 V1.0.00.....	Version of each IC	
Set	Reset	All Pan&Tilt :	Reset all Reset Pan&Tilt :
	Movement	Pan Reverse① Tilt Reverse① Pan Degree① Encoders① Pan/Tilt Mode①	ON/OFF ON/OFF 630/540 ON/OFF Stand/Smooth

	UI Set	Mic Sens. ③ No Signal① Temperature. C/F① Fans Mode① Hibernation① Backlight① Flip Display① Display Bright③ Brand Show① Key Lock① Language③	0~99%,60% Close/Hold/Auto/Music Fahrenheit /Celsius Auto Speed /High Speed OFF, 01M~99M, 15M 02~60m 02m ON/OFF 00~31 10 ON/OFF ON/OFF En/Fr/Sp/簡/繁	Sensitivity of Mic Mode when no signal Temperature at °C/°F Fans mode Sleeping mode Show backlight time Display 180° reverse Display Brightness Show brand or not Key lock on/off Language Select
	Fixture Set (Only Led Lamp)	Theater Mode Dimmer Curve Halogen(Only RGB Led)	ON/OFF Curve1..... Off/2700k/3200k/5600k	Theater Mode Dimmer Curve(Only Led) Halogen(Only RGB Led)
	Users	User Mode①	Standard Extended : User	Standard mode Extended mode : User program mode
		Edit User③	Max Channel = XX PAN = CH01 :	Edit users mode
	Calibration③	-Password- Pan :	=XXX =XXX :	Password: 050 Calibrate channel value
	Fixture ID③	Name -Password- PID Code		Name Password: 050 Set PID of RDM
	Wireless Set① (Wireless Module)	DMX On Cable Reset Connect	ON/OFF ON/OFF	DMX Send Out Reset Connect
	Ethernet Set③ (Only Artnet Module)	IP Address IP Mask Universe DMX On Cable	2.x.x.x 255.0.0.0 0 ON/OFF	Ethernet Set (Only Artnet Module)
	Reload Default	Basic Reload(①) Program Reload(②) ---Password--- Private Reload(③) All Reload Update Fixture	ON/OFF ON/OFF XXX ON/OFF ON/OFF ON/OFF	Basic Reload Program Reload Password: 050 Private Reload All Reload Software upgrade
Program	Play①	DMX Receive Slave Receive Sequence Music	Slave Receive 1,2,3 Master / Alone Master / Alone	DMX Receive Choose slave position Run Sequence Music mode
	Select Chase②	Chase Part 1 Chase Part 2 Chase Part 3	Chase 1 ~ 8 Chase 1 Chase 1 ~ 8 Chase 2 Chase 1 ~ 8 Chase 3	Select and run auto program

	Edit Chase②	Chase 1 : Chase 8	Chase Test Step 01 Step 64	=SCxxx =SCxxx	Test Beginning scene Ending scene
	Edit Scenes②	Edit Scene 001 ~ Edit Scene 250	Pan,Tilt,..... --Fade Time-- --Secne Time-- DMX Input	=xxx =xxx =xxx	Input manual scene Modify manually fading time Modify manually scene time Input scene from exterior controller
	Scenes Record	ScXX=>ScXX			Auto Input scenes

5. DMX connection and DMX protocol

5.1 DMX addressing:

5.1.1 The device is controlled by universal DMX 512 protocol, DMX address is the start channel used to receive instructions from the external controller. For independent control, each fixture must be assigned its unique address control channels. For example, this device has four channel modes: 31/32/18/20, if we set the mode at standard 31 channels mode, and there are several models need to be independently controlled, we just simply address first fixture at 1, and second fixture at 32, third one at 63, etc.

If the devices have the same address, they will behave synchronically.

DMX addressing is limited, don't set the address so high that without enough control channels for the fixtures.

Display is flashing when no DMX signal is received.

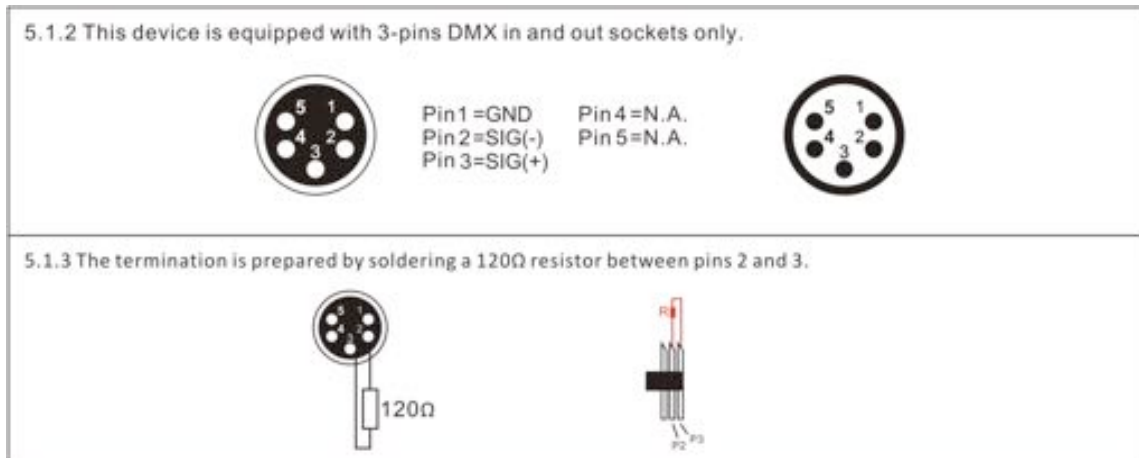

5.1.4 Connection: us DMX cable with 5 pin XLR-plugs to connect the controller with the fixture or one fixture with another.

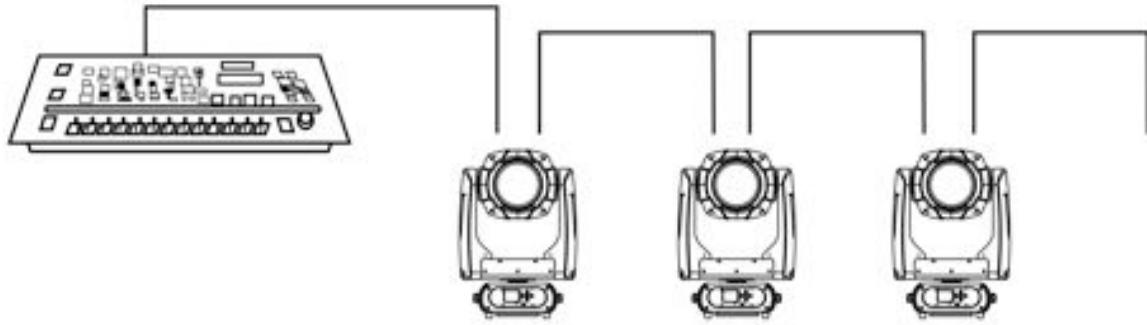

5.2 DMX chart

Channel				name	function	Min DMX	Max DMX
St	Ex	Ba1	Ba2				
1	1	1	1	Pan	Pan Coarse	0	255
2	2		2	Pan fine	Pan Fine	0	255
3	3	2	3	Tilt	Tilt Coarse	0	255
4	4		4	Tilt fine	Tilt Fine	0	255
5	5	3	5	Movement Speed	fastest to Slowest	0	255
	6			Movement Function	Normal	0	15
					Movement With Backout	16	31
					TBD	32	255
6	7			Shutter Function	Normal Shutter Functions	0	15
					Pulse-effect Forward	16	31
					Pulse-effect Reverse	32	47
					Random Strobe	48	63
					TBD	64	255
7	8			Shutter	Normal Shutter Functions		
					Close	0	31
					Strobe Rate (slow to fast)	32	223
					Open	224	255
					Pulse-effect Forward		
					Close	0	31
					Strobe Rate (slow to fast)	32	223
					Open	224	255
					Pulse-effect Reverse		
					Close	0	31
					Strobe Rate (slow to fast)	32	223
					Open	224	255
					Random Strobe		
					Close	0	31
					Strobe Rate (slow to fast)	32	223
				Open	224	255	

					Shutter closed	0	31
					No function (shutter open)	32	63
					Strobe effect slow to fast	64	95
		4	6	Shutter	No function (shutter open)	96	127
					Pulse-effect in sequences	128	159
					No function (shutter open)	160	191
					Random strobe effect slow to fast	192	223
					No function (shutter open)	224	255
8	9	5	7	Dimmer	Dimmer(Close to Open)	0	255
					Indexed	0	15
					Indexed With BackOut	16	31
					Forward Spin	32	47
					Reverse Spin	48	63
					Continuous	64	79
					Color Bounce	80	111
					TBD	112	255
					Indexed & Indexed With BackOut&Color Bounce		
					Position 1 (Open)	0	20
					Position 2	21	41
					Position 3	42	62
					Position 4	63	83
					Position 5	84	104
					Position 6	105	125
					Position 7	126	146
					Position 8	147	167
					Position 9	168	188
					Position 10	189	209
					Position 11	210	230
					Position 12	231	255
					Forward Spin		
					Stop to fastest	0	255
					Reverse Spin		
					Stop to fastest	0	255
					Continuous		
					Positioning from 0-360 degrees	0	255
					Indexed		
					Cyan 0->100%	0	127
					Position 1	128	129
					Position 2	130	131
					Position 3	132	133
					Position 4	134	135
					Position 5	136	137
					Position 6	138	139
					Position 7	140	141
					Position 8	142	143
					Position 9	144	145

				Position 10	146	147
				Position 11	148	149
				Indexed With Bounce		
				Position 1	150	159
				Position 2	160	169
				Position 3	170	179
				Position 4	180	189
				Position 5	190	199
				Position 6	200	209
				Position 7	210	223
				Forward Wheel Spin		
				Stop to fastest	224	239
				Reverse Wheel Spin		
				Stop to fastest	240	255
11	12			Color2 Function		
				Indexed	0	15
				Indexed With BackOut	16	31
				Forward Spin	32	47
				Reverse Spin	48	63
				Continuous	64	79
				Color Bounce	80	111
				TBD	112	255
12	13			Color2		
				Indexed & Indexed With BackOut&Color Bounce		
				Position 1 (Open)	0	20
				Position 2	21	41
				Position 3	42	62
				Position 4	63	83
				Position 5	84	104
				Position 6	105	125
				Position 7	126	146
				Position 8	147	167
				Position 9	168	188
				Position 10	189	209
				Position 11	210	230
				Position 12	231	255
				Forward Spin		
				Stop to fastest	0	255
				Reverse Spin		
				Stop to fastest	0	255
				Continuous		
				Positioning from 0-360 degrees	0	255
		7	9	Color2& Magenta		
				Indexed		
				Magenta 0->100%	0	127
				Position 1	128	129
				Position 2	130	131
				Position 3	132	133
				Position 4	134	135

					Position 5	136	137
					Position 6	138	139
					Position 7	140	141
					Position 8	142	143
					Position 9	144	145
					Position 10	146	147
					Position 11	148	149
					Indexed With Bounce		
					Position 1	150	159
					Position 2	160	169
					Position 3	170	179
					Position 4	180	189
					Position 5	190	199
					Position 6	200	209
					Position 7	210	223
					Forward Wheel Spin		
					Stop to fastest	224	239
					Reverse Wheel Spin		
					Stop to fastest	240	255
13	14			Color3 Function	Indexed	0	15
					Indexed With BackOut	16	31
					Forward Spin	32	47
					Reverse Spin	48	63
					Continuous	64	79
					Color Bounce	80	111
					TBD	112	255
14	15			Color3	Indexed & Indexed With BackOut&Color Bounce		
					Position 1 (Open)	0	20
					Position 2	21	41
					Position 3	42	62
					Position 4	63	83
					Position 5	84	104
					Position 6	105	125
					Position 7	126	146
					Position 8	147	167
					Position 9	168	188
					Position 10	189	209
					Position 11	210	230
					Position 12	231	255
					Forward Spin		
					Stop to fastest	0	255
					Reverse Spin		
					Stop to fastest	0	255
					Continuous		
					Positioning from 0-360 degrees	0	255
		8	10	Color3&	Indexed		

			Yellow	Yellow 0->100%	0	127
				Position 1	128	129
				Position 2	130	131
				Position 3	132	133
				Position 4	134	135
				Position 5	136	137
				Position 6	138	139
				Position 7	140	141
				Position 8	142	143
				Position 9	144	145
				Position 10	146	147
				Position 11	148	149
				Indexed With Bounce		
				Position 1	150	159
				Position 2	160	169
				Position 3	170	179
				Position 4	180	189
				Position 5	190	199
				Position 6	200	209
				Position 7	210	223
				Forward Wheel Spin		
				Stop to fastest	224	239
				Reverse Wheel Spin		
				Stop to fastest	240	255
15	16		Cyan	Cyan 0->100%	0	255
16	17		Magenta	Magenta 0->100%	0	255
17	18		Yellow	Yellow 0->100%	0	255
18	19		Rot Gobo Function	Indexed	0	15
				Indexed With BackOut	16	31
				Forward Spin	32	47
				Reverse Spin	48	63
				Continuous	64	79
				Shake	80	95
				TBD	96	255
19	20		Rot Gobo	Indexed & Indexed With Backout&Shake		
				Position 1 (Open)	0	35
				Position 2	36	71
				Position 3	72	107
				Position 4	108	143
				Position 5	144	179
				Position 6	180	215

					Position 7	216	255
					Forward Wheel Spin		
					Stop to fastest	0	255
					Reverse Wheel Spin		
					Stop to fastest	0	255
					Continuous		
					Positioning from 0-360 degrees	0	255
					Indexed		
					Position 1 (Open)	0	6
					Position 2	7	13
					Position 3	14	20
					Position 4	21	27
					Position 5	28	34
					Position 6	35	41
					Position 7	42	48
					Indexed With Backout		
					Position 1 (Open)	49	55
					Position 2	56	62
					Position 3	63	69
					Position 4	70	76
					Position 5	77	83
					Position 6	84	90
					Position 7	91	97
					Indexed With Shake		
					Position 2	98	118
					Position 3	119	139
					Position 4	140	160
					Position 5	161	181
					Position 6	182	202

					Position 7	203	223
					Forward Wheel Spin		
					Stop to fastest	224	239
					Reverse Wheel Spin		
					Stop to fastest	240	255
20	21			Gobo Rot Function	Continuous	0	15
					Forward Spin	16	31
					Reverse Spin	32	47
					Forward Animate Rotate	48	63
					Forward Animate Rotate With Backout	64	79
					Reverse Animate Rotate	80	95
					Reverse Animate Rotate With Backout	96	111
					TBD	112	255
21	22			Gobo Rot	Continuous		
					Positioning from 0-360 degrees	0	255
					Forward Spin		
					Stop to fastest	0	255
					Reverse Spin		
					Stop to fastest	0	255
					Forward Animate Rotate & Forward Animate Rotate With Backout		
					Stop to fastest	0	255
					Reverse Animate Rotate & Reverse Animate Rotate With Backout		
					Stop to fastest	0	255
		10	12	Gobo Rot	Continuous		
					Positioning from 0-360 degrees	0	191
					Forward Animate Rotate		
					Stop to fastest	192	207
					Reverse Animate Rotate		
					Stop to fastest	208	223
					Forward Spin		
					Stop to fastest	224	239
					Reverse Spin		
Stop to fastest	240	255					
22	23			Gobo Function	Indexed	0	15
					Indexed With BackOut	16	31
					Forward Spin	32	47
					Reverse Spin	48	63
					Continuous	64	79
					Shake	80	95
					TBD	96	255
23	24			Fixed Gobo	Indexed & Indexed With Backout&Shake		
					Position 1 (Open)	0	12

					Position 2	13	25
					Position 3	26	38
					Position 4	39	51
					Position 5	52	64
					Position 6	65	77
					Position 7	78	90
					Position 8	91	103
					Position 9	104	116
					Position 10	117	129
					Position 11	130	142
					Position 12	143	155
					Position 13	156	168
					Position 14	169	181
					Position 15	182	194
					Position 16	195	207
					Position 17	208	220
					Position 18	221	233
					Position 19	234	255
					Forward Wheel Spin		
					Stop to fastest	0	255
					Reverse Wheel Spin		
					Stop to fastest	0	255
					Continuous		
					Positioning from 0-360 degrees	0	255
				Fixed Gobo	Indexed		
					Position 1 (Open)	0	1
					Position 2	2	3
					Position 3	4	5

Position 4	6	7
Position 5	8	9
Position 6	10	11
Position 7	12	13
Position 8	14	15
Position 9	16	17
Position 10	18	19
Position 11	20	21
Position 12	22	23
Position 13	24	25
Position 14	26	27
Position 15	28	29
Position 16	30	31
Position 17	32	33
Position 18	34	35
Position 19	36	37
Indexed With Backout		
Position 1 (Open)	38	39
Position 2	40	41
Position 3	42	43
Position 4	44	45
Position 5	46	47
Position 6	48	49
Position 7	50	51
Position 8	52	53

Position 9	54	55
Position 10	56	57
Position 11	58	59
Position 12	60	61
Position 13	62	63
Position 14	64	65
Position 15	66	67
Position 16	68	69
Position 17	70	71
Position 18	72	73
~ Position 19	74	75
Indexed With Shake		
Position 2	76	83
Position 3	84	91
Position 4	92	99
Position 5	100	107
Position 6	108	115
Position 7	116	123
Position 8	124	131
Position 9	132	139
Position 10	140	147
Position 11	148	155
Position 12	156	163
Position 13	164	171
Position 14	172	179

					Position 15	180	187
					Position 16	188	195
					Position 17	196	203
					Position 18	204	211
					Position 19	212	223
					Forward Wheel Spin		
					Stop to fastest	224	239
					Reverse Wheel Spin		
					Stop to fastest	240	255
24	25	12	14	Prism	Indexed & Indexed With Backout		
					Position 1 (Open)	0	85
					Position 2	86	171
					Position 3	172	255
25	26	13	15	Prism Rot	Continuous		
					Positioning from 0-360 degrees	0	191
					Forward Spin		
					Stop to fastest	192	223
					Reverse Spin		
					Stop to fastest	224	255
26	27	14	16	Frost	Continuous		
					Frost 0->100%	0	255
27	28			Focus Function	Continuous	0	15
					5m Auto Focus	16	31
					7.5m Auto Focus	32	47
					10m Auto Focus	48	63
					15m Auto Focus	64	79
					>20m Auto Focus	80	95
					TBD	96	255
28	29	15	17	Focus	Continuous		
					Focus In to Focus Out	0	255
					Auto Focus		
					Focus In to Focus Out Fine	0	255
29	30	16	18	Zoom	Continuous		
					Zoom Small to Big	0	255
					Auto Focus		
					Zoom In to Zoom Out Fine	0	255
30	31	17	19	Animation	Position 1 (Open)	0	3
					Forward Spin		
					Stop to fastest	0	127
					Reverse Spin		
					Stop to fastest	128	255
31	32	18	20	Control	Normal	0	7
					Reset All	8	15

				Pan&Tilt Reset	16	23
				Color Reset	24	31
				Gobo Reset	32	39
				TBD	40	47
				Other Reset	48	55
				Display Off	56	63
				Display On	64	71
				Lamp Off	72	79
				Lamp On	80	87
				Hibernation	88	95
				TBD	96	255

6. Unique Features

6.1 RDM, stand for “Remote Device Management”, with this function, users can realize remote control of the device, such as remotely changing DMX address, reverse pan/tilt setting, check a lot of useful information such as temperature, power consumption, fan speed. Etc. Every single device has a unique RDM code before left factory to distinguish from each other, usually not suggest users change this code freely.

6.2 Software upgrade function via DMX cable, if there is any new firmware for this device come out, it can be upgraded simply via a software upgrade box, no need to change any mechanical parts. The upgrade box is not included in the package, if need any further assistance pls just contact authorized dealers.

6.3 Hibernation, the device will enter sleeping mode if activated after a period of disconnecting DMX signal to save the power consumption, and will return immediately as soon as the DMX signal is sent again.

6.4 Display battery, this function is prepaid in the display PCB, users just need to install a normal 10440 600mAh 3.7V rechargeable lithium battery, then users could power on the display and do setting without connect to main power.

6.5 Display back-up communication IC, there is a back-up communication IC installed in the display PCB, so users could replace at once if the working one is broken, no need to wait long time from service.

6.6 Display flip, by press up and down button for more than 3 seconds, the display will flip automatically, this function is useful to read menu conveniently when device is hanged.

8. Dimensions Drawing

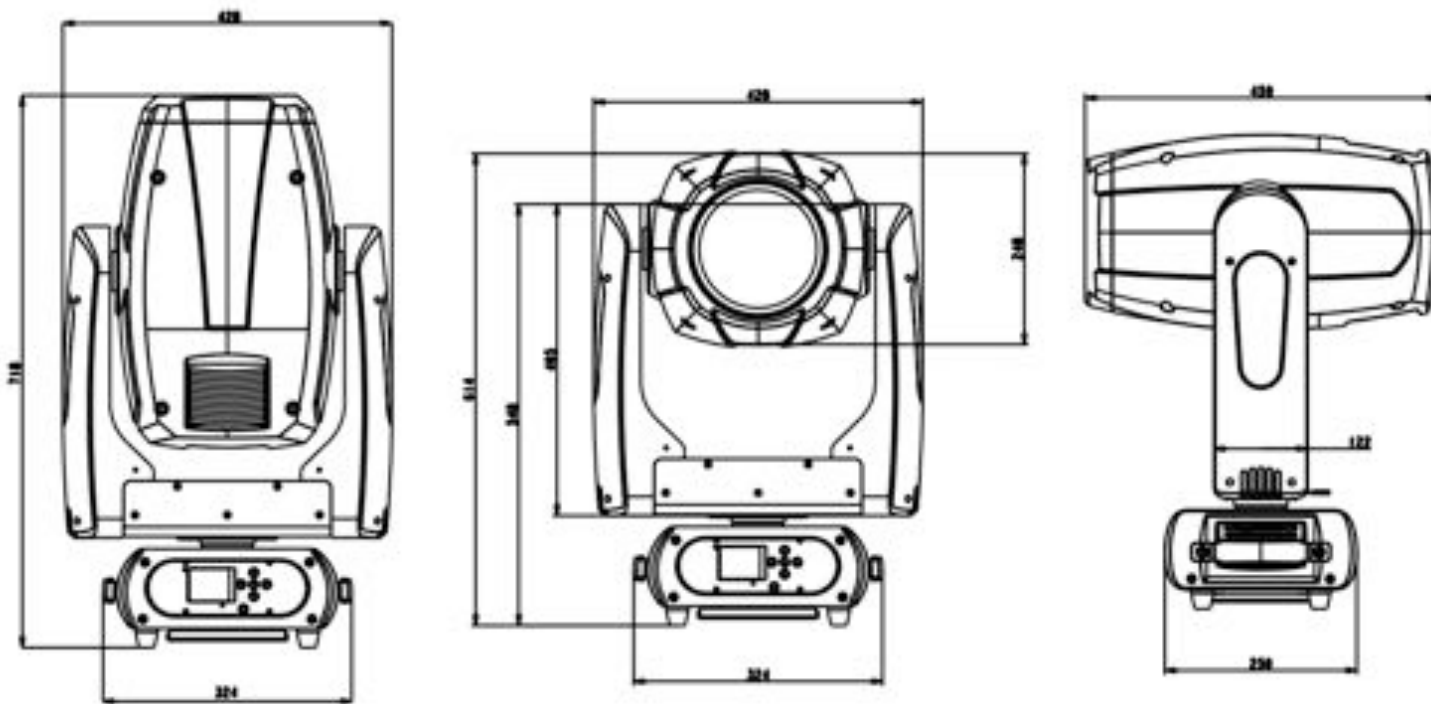

9. Technical specification

Power supply	100-240 V AC, 50/60 Hz ~
Power consumption	700W
LED	Osram Sirius HRI 440W discharge lamp
DMX channels	31/32/18/20 modes
Beam angle	2°-34° beam
Luminous flux	24000lumen
Fuse	T 8 A, 250 V
Device dimensions	428x324x718mm
Net Weight	25KG