

BSL THEATER FRESNEL

MANUAL



Unpacking: Thank you for purchasing our products. Every unit has been thoroughly tested and has been shipped in perfect operating condition. Carefully check the shipping carton for damage that may have occurred during shipping. If the carton appears to be damaged, carefully inspect your fixture for any damage and be sure all accessories necessary to operate the unit has arrived intact. In the case damage has been found or parts are missing, please contact the manufacturer or your dealer for further instructions. Do not return this unit to your dealer without first contacting. **FOR YOUR OWN SAFETY, PLEASE READ THIS USER MANUAL CAREFULLY BEFORE POWERING OR INSTALLING AEGLE. SAVE IT FOR FUTURE REFERENCE.**

PLEASE consider that damages caused by manual modifications to the device are not subject to warranty.

Caution! There are no user serviceable parts inside this unit. Do not attempt any repairs yourself; doing so will void your manufactures warranty. In the unlikely event your unit may require service please contact the manufacturer or your dealer.

PLEASE recycle the shipping carton whenever possible.

General Instructions: To optimize the performance of this product, please read these operating instructions carefully to familiarize you with the basic operations of this unit. These instructions contain important safety information regarding the use and maintenance of this unit.

Features

- Electronic Dimming 0-100%
- DMX-512 protocol
- Master/Slave synchronization
- Sound Control
- LED operation menu with function buttons
- Daisy Chain Units Together in DMX Mode

Safety Precautions

- To reduce the risk of electrical shock or fire, do not expose this unit to rain or moisture.
- Do not spill water or other liquids into or on to your unit.
- Be sure that the local power outlet matches that of the required voltage for your unit.
- Do not attempt to operate this unit if the power cord has been frayed or broken. Do not attempt to remove or break off the ground prong from the electrical cord. This prong is used to reduce the risk of electrical shock and fire in case of an internal short.
- Disconnect from main power before making any type of connection.
- Do not remove the cover under any conditions. There are no user serviceable parts inside.
- Never operate this unit when it's cover is removed.
- Never plug this unit in to a dimmer pack.
- Always be sure to mount this unit in an area that will allow proper ventilation. Allow about 6" (15cm) between this device and a wall.
- Do not attempt to operate this unit, if it becomes damaged.
- This unit is intended for indoor use only; use of this product outdoors voids all warranties.
- During long periods of non-use, disconnect the unit's main power.
- Always mount this unit in safe and stable matter.
- Power-supply cords should be routed so that they are not likely to be walked on or pinched by items placed upon or against them, paying particular attention to the point they exit from the unit.
- Cleaning -The fixture should be cleaned only as recommended by the manufacturer. See "Cleaning" for details.

- Heat -The appliance should be situated away from heat sources such as radiators, heat registers, stoves, or other appliances (including amplifiers) that produce heat.
- The fixture should be serviced by qualified service personnel when:
 - A. The power-supply cord or the plug has been damaged.
 - B. Objects have fallen, or liquid has been spilled into the appliance.
 - C. The appliance has been exposed to rain or water.
 - D. The appliance does not appear to operate normally or exhibits a marked change in performance.

Set Up:

Power Supply: Before plugging your unit in, be sure the source voltage in your area matches the required voltage for your device, the model is Auto power supply, it is workable at 90-250V/50~60Hz. Please make sure your unit voltage matches the wall outlet voltage before attempting to operate your fixture.

Connection to the mains

For protection from electric shock, the fixture must be earthed!

Install a suitable plug on the power cord; note that the cores in the power cord are colored according to the following table. The earth has to be connected!

If you have any doubts about proper installation, consult a qualified electrician.

Core (EU)	Core (US)	Connection	Plug Terminal Marking
Brown	Black	Live	L
Light blue	White	Neutral	N
Yellow/Green	Green	Earth	

DMX512 connection

The fixture is equipped with 3-pin or 5-pin XLR sockets for DMX input and output. The sockets are wired in parallel.

Only use a shielded twisted-pair cable designed for RS-485 and 3-pin or 5-pin XLR-plugs and connectors in order to connect the controller with the fixture or one fixture with another.

DMX-output

XLR mounting-sockets (rear view):

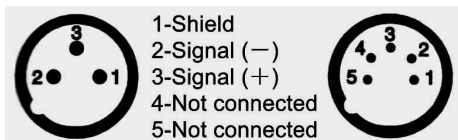

DMX-input

XLR mounting-plugs (rear view):

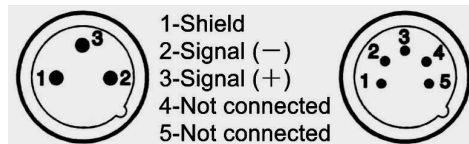

DMX Linking: To ensure proper DMX data transmission, when using several DMX fixtures try to use the shortest cable path possible. The order in which fixtures are connected in a DMX line does not influence the DMX addressing. For example; a fixture assigned a DMX address of 1 may be placed anywhere in a DMX line, at the beginning, at the end, or anywhere in the middle. When a fixture is assigned a DMX address of 1, the DMX controller knows to send DATA assigned to address 1 to that unit, no matter where it is located in the DMX chain.

Operating Modes: You can use this device in 3 ways:

- Auto Mode - The unit will automatically chase through the different colors and built-in programs.
- Slave Mode – The unit will run under slave mode.
- DMX control mode - This function will allow you to control each individual fixtures traits with a standard DMX 512 controller.

DMX Mode: Operating through a DMX controller give the user the freedom to create their own programs tailored to their own individual needs. This function also allows you to use your fixtures as spot lights.

1. This function will allow you to control each individual fixture’s traits with a standard DMX 512 controller.
2. It uses 3 dmx channels to operate. Please see “DMX Values and Functions” for the DMX traits.
3. To run your fixture in DMX mode, plug in the fixture via the XLR connections to any standard DMX controller.
Set your desired DMX address following the setup specifications that come with your DMX controller

Main Control Menu

The control board on the fixture base is your interface to access and control all functions on the unit, its screen display gives you a code vide of functions

CONTROL BOARD

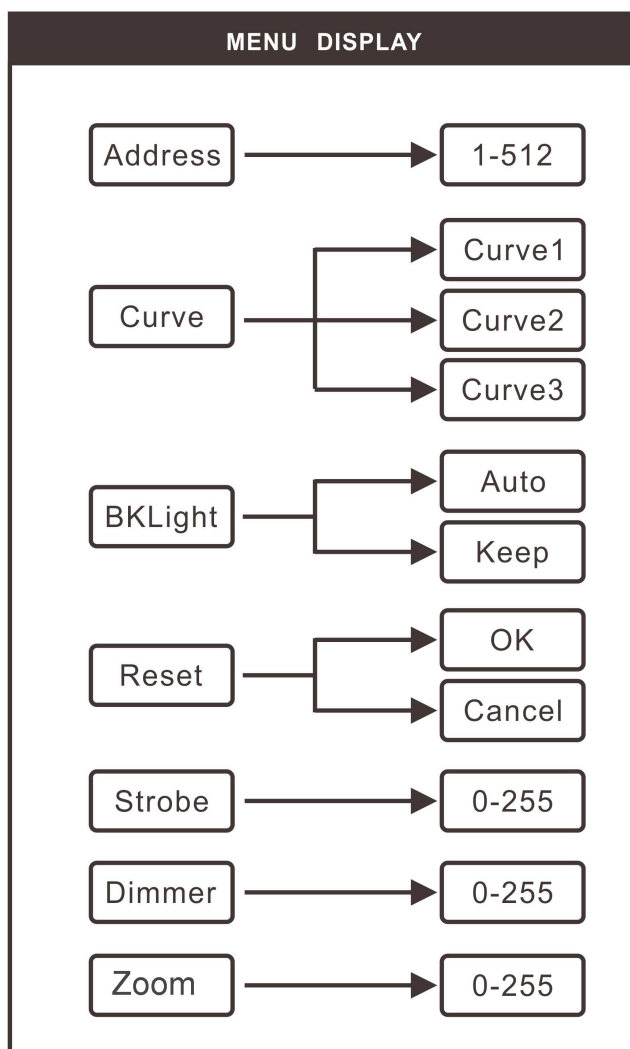

Address

DMX Address. Press Enter to select the start address channel. The first display will let you know what operation mode you are in. Use the Up/Down keys to select the desired start address. Press Enter to confirm.

Curve

Dimmer Mode This function allows you to select dimmer mode. Press Enter to use Up/Down keys to select desired Mode settings. Press Enter to confirm the setting

BKLight

Back Light This function allows you to make back light be OFF or ON after setting, Press Enter to use Up/Down keys to select desired Mode settings. Press Enter to confirm the setting

Reset

Reset This function allows you to make fixture be reset by manual, Press Enter to use Up/Down keys to select desired Mode settings. Press Enter to confirm the setting

Strobe

Strobe This function allows you to select strobe effect from 000-255, Press Enter to use Up/Down keys to select desired effect settings. Press Enter to confirm the setting

Dimmer

Dimmer This function allows you to select LED intensity from 000-255, Press Enter to use Up/Down keys to select desired intensity settings. Press Enter to confirm the setting.

Zoom

Zoom This function allows you to select zoom angle from 000-255, Press Enter to use Up/Down keys to select desired zoom range settings. Press Enter to confirm the setting

DMX Chart:

CHANNEL	VALUE	FUNCTION
1	0-255	Dimmer
2	0-255	Strobe
3	0-255	Zoom

Dimension(mm):

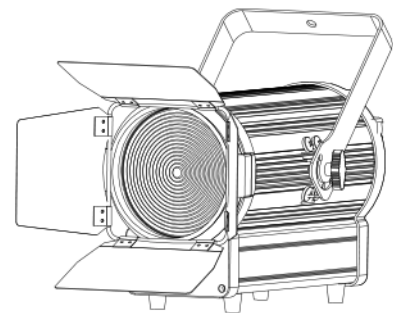
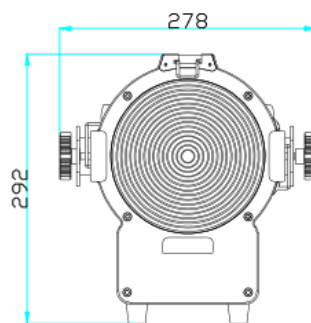
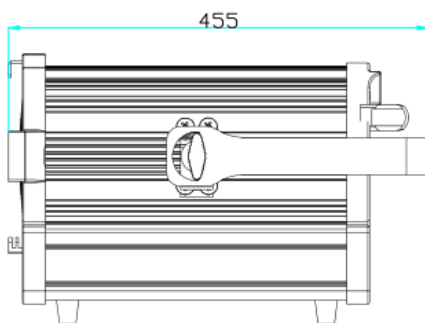

Cleaning

Due to fog residue, smoke, and dust cleaning the internal and external optical lenses must be carried out periodically to optimize light output.

1. Use normal glass cleaner and a soft cloth to wipe down the outside casing.
2. Clean the external optics with glass cleaner and a soft cloth every 20 days.
3. Always be sure to dry all parts completely before plugging the unit back in.

Cleaning frequency depends on the environment in which the fixture operates (i.e. smoke, fog residue, dust, dew).

TROUBLE SHOOTING:

Listed below are a few common problems the user may encounter, with solutions.

Unit not respond to DMX:

1. Check that the DMX cables are connected properly and are wired correctly (pin 3 is “hot”; on some other DMX devices pin 5 may be ‘hot’). Also, check that all cables are connected to the right connectors; it does matter which way the inputs and outputs are connected.

Specifications

Model: Theater Fresnel

Working Position: Any safe working position

Voltage: 90-250V / 50~60Hz

Power: 250W

LED Lamp: High power COB LED Warm White 250Watts

Electronic linear zoom: 15°-52°

Color temperature: 3200-3500K

DMX Channel: 3

CRI≥96

CCT: 3000-3200K

Protection Rating: IP20

Net Weight: 10.2Kgs

Warranty: 2 Year

Note: All information is subject to change without prior notice.